

Inlet Pulse Accumulator series

IPA/40, IPA/65 and IPA/100

Manual



© 2017 Watson-Marlow Bredel B.V.

All rights reserved.

The information provided herein may not be reproduced and/or published in any form, by print, photo print, microfilm or any other means whatsoever (electronically or mechanically) without the prior written authorization of Watson-Marlow Bredel B.V.

The information provided can be changed without prior notification. Watson-Marlow Bredel B.V. or one of its representatives cannot be held liable for possible damage resulting from use of this manual. This is an extensive limitation of the liability which applies to all damage, inclusive of (without limitation) compensating, direct, indirect or consequential damage, loss of data, income or profit, loss or damage to possessions and claims of third parties.

Watson-Marlow Bredel B.V. provides the information in this manual “as is” and does not take any responsibility and does not give any guarantee on this manual or its content. Watson-Marlow Bredel B.V. rejects all responsibilities and guarantees. Furthermore, Watson-Marlow Bredel B.V. does not take responsibility for and does not guarantee that information in this manual is accurate, complete or up to date.

Names, trade names, brands, etc. used by Watson-Marlow Bredel B.V. may not, as per the legislation concerning the protection of trade names, be considered as available.

CONTENTS

CONTENTS	3
1 GENERAL	4
1.1 <i>How to use this manual</i>	4
1.2 <i>Original instructions</i>	4
1.3 <i>Service and support</i>	4
1.4 <i>Environment and disposal of waste</i>	4
2 SAFETY	5
2.1 <i>Symbols</i>	5
2.2 <i>Intended use</i>	5
2.3 <i>Use In Potentially Explosive Environments (ATEX)</i>	5
2.4 <i>Responsibility</i>	6
2.5 <i>Qualification of the user</i>	6
2.6 <i>Regulations and instructions</i>	6
3 WARRANTY CONDITIONS	7
4 DESCRIPTION	8
4.1 <i>Identification of the product</i>	8
4.2 <i>Operation of the inlet pulse accumulator</i>	8
4.3 <i>Inlet pulse accumulator selection</i>	9
4.4 <i>Inlet pulse accumulator hose element</i>	10
5 INSTALLATION AND COMMISSIONING	11
5.1 <i>Unpacking</i>	11
5.2 <i>Inspection</i>	11
5.3 <i>Installation conditions</i>	11
5.3.1 <i>Ambient conditions</i>	11
5.3.2 <i>Set-up</i>	11
5.4 <i>Lifting and moving the inlet pulse accumulator</i>	12
6 MAINTENANCE	13
6.1 <i>Cleaning the inlet pulse accumulator hose element internally</i>	13
6.2 <i>Removing the inlet pulse accumulator hose element</i>	13
6.3 <i>Replacing the inlet pulse accumulator hose element</i>	14
7 TROUBLESHOOTING	15
8 SPECIFICATIONS	16
8.1 <i>General information</i>	16
8.2 <i>Torque values</i>	16
8.3 <i>Weights</i>	16
8.4 <i>Parts list</i>	16
8.5 <i>Dimensions Stainless Steel version</i>	18
8.6 <i>Dimensions PVC version</i>	20
9 SAFETY FORM	22

1 GENERAL

1.1 How to use this manual

This manual is intended as a reference book by means of which qualified users are able to install, commission, operate and maintain the inlet pulse accumulators mentioned on the front cover.

1.2 Original instructions

The original instructions for this manual have been written in English. Other language versions of this manual are a translation of the original instructions.

1.3 Service and support

For information with respect to specific adjustments, installation, maintenance or repair jobs which fall beyond the scope of this manual, contact your Bredel representative. Make sure you have the following information at hand:

- serial number of the inlet pulse accumulator
- type number of the inlet pulse accumulator

You will find this data on the identification plate of the inlet pulse accumulator (see paragraph *4.1 Identification of the product*).

1.4 Environment and disposal of waste



Enquire within your local government about the possibilities for reuse or environment friendly processing of packaging materials, (contaminated) lubricant and oil.

Always observe the local rules and regulations with respect to processing (non-reusable) parts of the pulsation damper

2 SAFETY

2.1 Symbols

In this manual the following symbols are used:

	<p>WARNING Procedures which, if not carried out with the necessary care, may result in serious damage to the inlet pulse accumulator or in serious bodily harm.</p>
	<p>CAUTION Procedures which, if not carried out with the necessary care, may result in serious damage to the inlet pulse accumulator, the surrounding area or the environment.</p>
	<p>Remarks, suggestions and advice.</p>
	<p>Procedures, remarks, suggestions or advice which refer to use in potentially explosive atmospheres (ATEX) in accordance with European guideline 2014/34/EU.</p>

2.2 Intended use

The inlet pulse accumulator is exclusively designed for the damping of pulses on the inlet side of a Bredel hose pump. Every other or further use is not in conformance with the intended use¹. The manufacturer cannot be held responsible for any damage or harm resulting from this. The inlet pulse accumulator is designed in conformance with the current European standards and directives. Only use the inlet pulse accumulator in conformance with the intended use described above. If you want to change the application of your inlet pulse accumulator, contact your Bredel representative first.

¹ The “intended use” as laid down in EN 292-1 is “...the use for which the technical product is intended in accordance with the specifications of the manufacturer, inclusive of his indications in the sales brochure”. In case of doubt it is the use which appears to be its intended use judging from the construction, execution and function of the product. Observing the instructions in the user’s documentation also belongs to intended use.

2.3 Use In Potentially Explosive Environments (ATEX)

The stainless steel versions of the inlet pulse accumulators IPA40, IPA65 and IPA100 can be used in a potentially explosive atmosphere (ATEX). The inlet pulse accumulator is not classed as ATEX equipment since it contains no ignition source from its own. It is considered as part of the pump and the ATEX code for the pump is applicable, meaning it can operate under the same ATEX environment as the pump it is attached to. When operating under ATEX pay extra attention to the following:

- Inlet pulse accumulator to be installed, operated and maintained according this manual (see chapter 8 *SPECIFICATIONS*).
- Make sure the damper is connected to the earth. In general this is the case when the damper is connected to the pump and the piping system. By construction all parts are electrically connected.

This can be checked by measuring the electrical resistance to the earth. The electrical resistance to any ground connection should be less than 1 MOhm.

- Exclude PVC versions of the inlet pulse accumulators from being applied in a potentially explosive atmosphere.



WARNING

In case it is not possible to create an earth/ground connection with less than 1 MOhm, one should make an additional PE (protective earth) connection to the inlet pulse accumulator. (see chapter 5 *INSTALLATION AND COMMISSIONING*).



WARNING

Do not apply PVC versions of the inlet pulse accumulators in a potentially explosive atmosphere.

2.4 Responsibility

The manufacturer does not accept any responsibility for damage or harm caused by not (strictly) observing the safety regulations and instructions in this manual or by negligence during installation, use, maintenance and repair of the inlet pulse accumulators mentioned on the front cover. Depending on the specific working conditions or accessories used, additional safety instructions can be required. Immediately contact your Bredel representative, if you notice a potential danger while using your inlet pulse accumulator.



WARNING

The user of the inlet pulse accumulator is always fully responsible for observing the local valid safety regulations and directives. Observe these safety regulations and directives when using the inlet pulse accumulator.

2.5 Qualification of the user

The installation, operation and maintenance of the inlet pulse accumulator should be carried out by well trained and qualified users. Temporary staff and persons in training may only use the inlet pulse accumulator under the supervision and responsibility of well trained and qualified users.

2.6 Regulations and instructions

- Everyone who works with the inlet pulse accumulator must be aware of the content of this manual and observe the instructions with great care.
- Never change the order of the actions to be carried out.
- Always store the manual near the inlet pulse accumulator.

3 WARRANTY CONDITIONS

The manufacturer offers a two year warranty on all parts of the inlet pulse accumulator. This means that all parts will be repaired or replaced free of charge with the exception of consumables, such as hose elements and seals, or parts which have been misused or have been intentionally damaged. If parts are used that are not Watson-Marlow Bredel B.V. (hereafter called Bredel) parts, every warranty becomes void.

Damaged parts which are covered by the applicable warranty conditions can be returned to the manufacturer. The parts must be accompanied by a fully filled in and signed safety form, as present in the back of this manual. The safety form must be applied to the outside of the shipping carton. Parts which have been contaminated or which have been corroded by chemicals or other substances which can pose a health risk, must be cleaned before they are returned to the manufacturer. Furthermore, it should be indicated on the safety form which specific cleaning procedure has been followed, and it should be indicated that the equipment has been decontaminated. The safety form is required at all items, even if the parts have not been used.

Warranties purporting to be on behalf of Bredel made by any person, including representatives of Bredel, its subsidiaries, or its distributors, which do not accord with the terms of this warranty shall not be binding upon Bredel unless expressly approved in writing by a Director or Manager of Bredel.

4 DESCRIPTION

4.1 Identification of the product

The inlet pulse accumulator and inlet pulse accumulator hose element type are indicated on the identification plate. The identification plate on the inlet pulse accumulator contains the following information, relevant for identification:

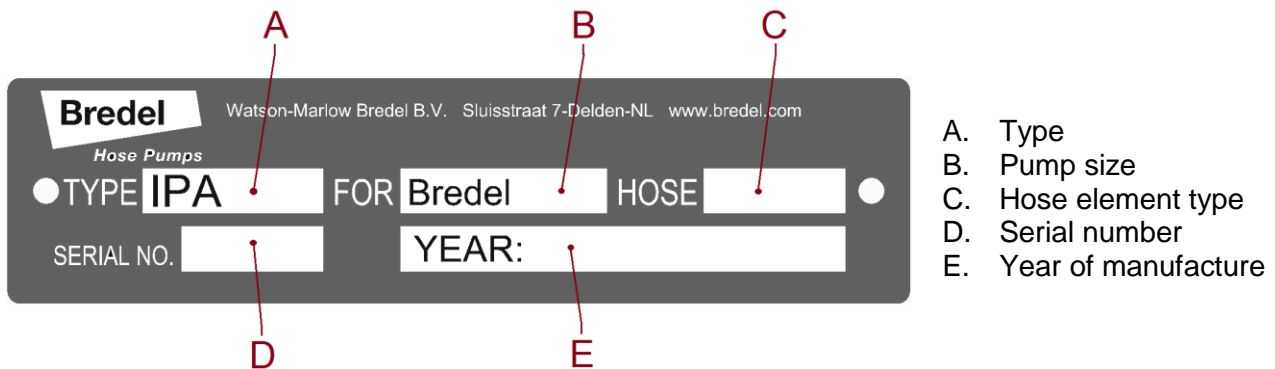

The label on the inlet pulse accumulator hose element contains following information:

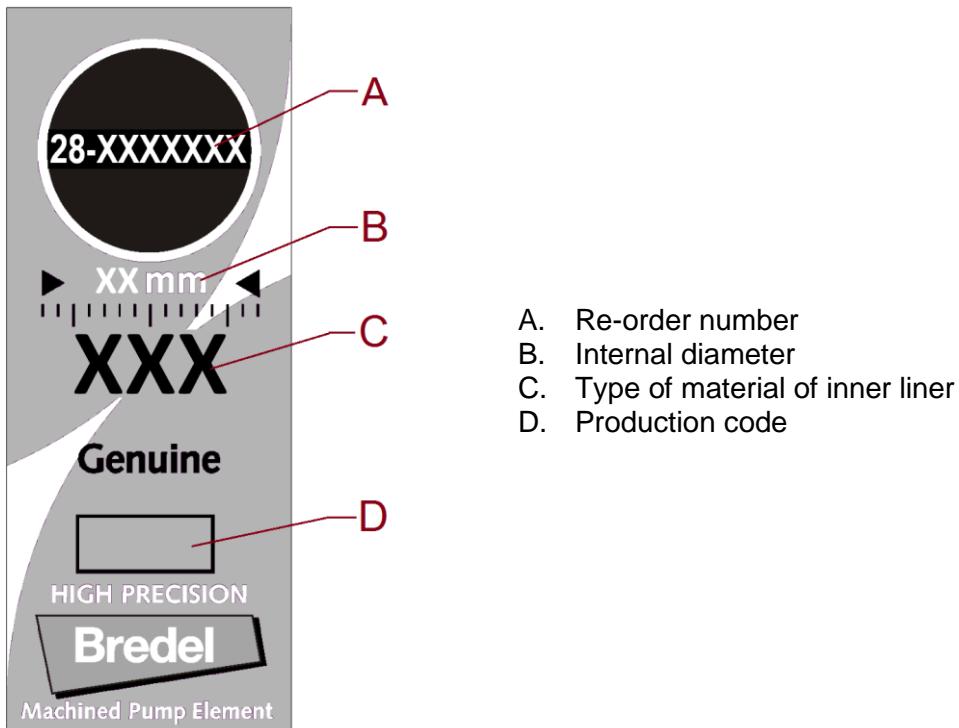

4.2 Operation of the inlet pulse accumulator

The Bredel inlet pulse accumulator reduces the pulses created in the inlet line by the hose pump. This is achieved by means of a reinforced rubber hose element which is mounted in a stainless steel, cylindrical protection housing. The hose element is surrounded by atmospheric air by means of a hole in the housing connecting the interior with the ambient conditions outside the accumulator.

Pulses are created when a pressing shoe enters the pump hose element, while rotating. Instantly the volume in the inlet line will decrease with the volume of the pressing shoe. This will result in a pressure rise in the inlet line.

When the inlet pressure rises, the inlet pulse accumulator hose element expands and compensates for the displaced volume of the pressing shoe in the inlet line. Hereby the pulse will be reduced. Dependent on the application the damper can reduce the pulse with 90%.

4.3 Inlet pulse accumulator selection

The inlet pulse accumulator types described in this manual are functional with more than one type of Bredel hose pumps. In the following table the right inlet pulse accumulator can be selected to match your hose pump.

Apply an inlet pulse accumulator if the inlet pulse exceeds the threshold given in the table.

An IPA is suitable for pumps with fixed or variable speeds and fixed or variable input pressures.

Selection table pump and inlet pulse accumulator			
Inlet pulse accumulator type	Pump type	Pump inlet pulse threshold	
		[kPa]	[psi]
IPA40/25	Bredel 25, APEX28	40	5.80
IPA40/32	Bredel 32, APEX35	40	5.80
IPA40/40	Bredel 40	30	4.35
IPA65/50	Bredel 50	30	4.35
IPA65/65	Bredel 65	30	4.35
IPA100/80	Bredel 80	20	2.90
IPA100/100	Bredel 100	10	1.45

IPA40/25, IPA40/32 and IPA40/40 have different connections suitable for the pumps mentioned, but have the same size for the hose element.

IPA65/50 and IPA65/65 have different connections suitable for the pumps mentioned and have different sizes (lengths) for the hose element.

IPA100/80 and IPA100/100 have different connections suitable for the pumps mentioned and have different sizes (lengths) for the hose element.



If you are in doubt about the correct installation of your inlet pulse accumulator, contact your Bredel representative for assistance. They will advise about the installation layout, pipe diameters, etc., to ensure optimum performance of your system.

4.4 Inlet pulse accumulator hose element

The inlet pulse accumulator hose element liner material should be chemically resistant to the product to be pumped. Dependent on the specific requirements of your application, a matching hose element must be selected.

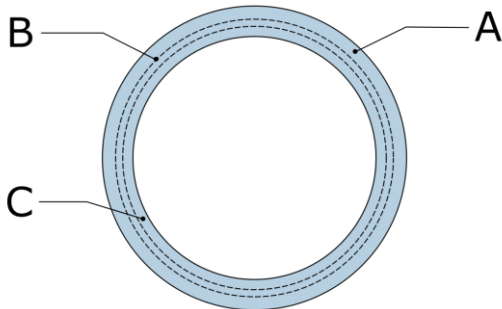

- A. Outer extruded layer made of natural rubber
- B. Two nylon reinforcement layers
- C. Inner extruded liner

For each inlet pulse accumulator, various hose element types are available. The material of the inner liner of the hose element determines the hose element type. Each hose element type is marked by a unique colour code.

Hose element type	Material	Colour code	Article number:				
			IPA40/25 IPA40/32 IPA40/40	IPA65/50	IPA65/65	IPA100/80	IPA100/100
NR	Natural rubber	Purple	28-IP04004020	28-IP06505020	28-IP06506520	28-IP10008020	28-IP10010020
NBR	Nitrile rubber	Yellow	28-IP04004040	28-IP06505040	28-IP06506540	28-IP10008040	28-IP10010040
EPDM	EPDM	Red	28-IP04004075	28-IP06505075	28-IP06506575	28-IP10008075	28-IP10010075



Consult your Bredel representative for more detailed information about the chemical and temperature resistance of inlet pulse accumulator hose elements.



Store the inlet pulse accumulator hose element in a cool, dry place and do not subject it to sunlight.

5 INSTALLATION AND COMMISSIONING

5.1 Unpacking

When unpacking carefully follow the instructions as given on the packaging or on any accompanying documents. Dispose of packaging materials safely, in accordance with regulations in your area, and without unnecessarily harming the environment.

5.2 Inspection

Check that your delivery is correct and check it for any transport damage (see also paragraph 4.1 *Identification of the product*).

5.3 Installation conditions

5.3.1 Ambient conditions

Make sure the ambient temperature, during normal operation of the inlet pulse accumulator, does not fall to below -20 °C, and does not exceed +45 °C.

5.3.2 Set-up

When installing the inlet pulse accumulator consider the following points:

- The flexibility of the hose element is the key factor for the dampening effect. The hose element will have the best possibility to breath when the inlet pressure is between 50 kPa (0.5 bar, 7 psi) and 150 kPa (1.5 bar, 22 psi). See paragraph 4.3 *Inlet pulse accumulator selection* for when to apply an inlet pulse accumulator.
- Limit the presence of sharp bends. Make sure that the radius of the bent inlet line is as large as possible. It is recommended to use Y-connections instead of T-connections.
- The inlet pulse accumulator will be most effective if it is directly mounted onto the hose pump. Minimise the distance between pump and inlet pulse accumulator.
- The inlet pulse accumulator must be installed with the housing in the vertical position. In this way sedimentation of product in the accumulator is avoided. IPA40 on pump models Bredel 25 and Bredel 32 (position 1 or 2) has to be installed at a tilt angle to prevent interference with the discharge line. See the picture.
- The housing has a red marked breather hole. This hole must remain open in order to allow the hose element to breath.
- The inlet pulse accumulator must be electrically connected to earth. (Resistance less than 1 MOhm). If required make a PE connection to the inlet pulse accumulator. The PE wire can be connected to one of the bolts attaching protection hood to the connection base.

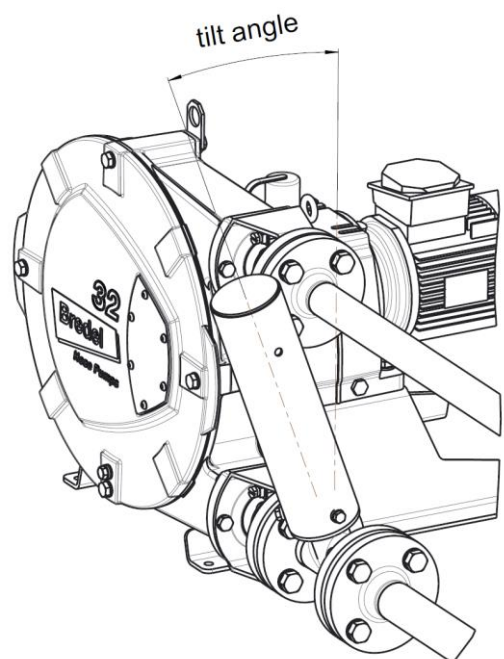



If installed in a potentially explosive atmospheres, properly earth the inlet pulse accumulator and respect the instructions as mentioned in paragraph 2.3 *Use In Potentially Explosive Environments (ATEX)*

- When using a Bredel series 265-2100 pump apply two inlet pulse accumulators - one for each pump head.
- Maximum allowable pressure is 350 kPa (3.5 bar, 50 psi).
- Avoid heavy loads on the flanges.

5.4 Lifting and moving the inlet pulse accumulator

To lift, move and position the inlet pulse accumulator, suitable hoisting belts must be used. The best place to attach the hoisting belt is immediately around the base between flanges and tube of the inlet pulse accumulator. Keep in mind the inlet pulse accumulator's weight. When lifting the inlet pulse accumulator will hang down.

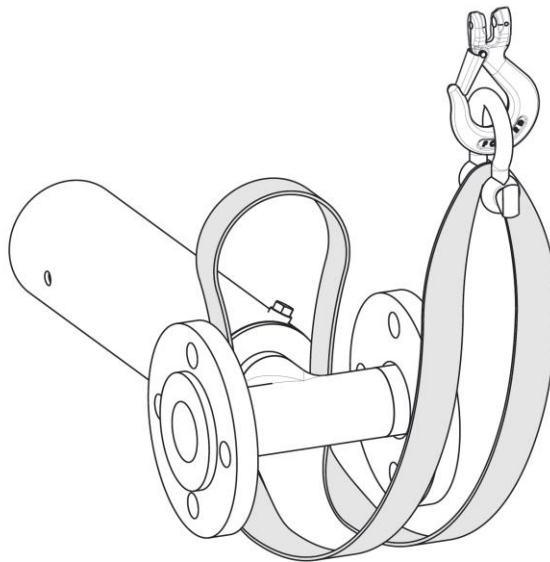

At installation follow the next steps:

1. Lift the accumulator till the flanges are in place between pump and inlet line.
2. Mount the flanges with the fasteners not tightened.
3. Remove the hoisting belt.
4. Rotate the accumulator in the upright position manually.
5. Tighten the flange fasteners.

For weights see also paragraph 8.3 *Weights*. For fastener tightening torques see paragraph 8.2 *Torque values*.



WARNING

If the inlet pulse accumulator is to be lifted, ensure that all safety regulations for lifting movements are adhered to and that the lifting is carried out by qualified personnel only.

6 MAINTENANCE

Careful maintenance and, in particular, proper cleaning are essential for problem-free operation of the inlet pulse accumulator.

- Before carrying out any maintenance to the inlet pulse accumulator, please acquaint yourself with the directives in the chapter 2 *SAFETY*.
- Any repair to the inlet pulse accumulator is to be carried out by skilled and authorised persons only.
- After cleaning and maintenance work, do not use the inlet pulse accumulator until all parts that have been removed, are reinstalled correctly.



WARNING

Protect your hands and face from any dangerous substances when handling or examining the inlet pulse accumulator hose element. After hose element rupture the product may come out of the breather hole.



CAUTION

After maintenance has been carried out, and before switching the pump back on, ensure that all valves present in the pipe work are opened.

6.1 Cleaning the inlet pulse accumulator hose element internally

The inside of the inlet pulse accumulator hose element cannot be cleaned by flushing the pump and inlet pulse accumulator with clean water. The protecting hood and the hose element must be disassembled in order to clean the interior. See 6.2 *Removing the inlet pulse accumulator hose element* and 6.3 *Replacing the inlet pulse accumulator hose element* for disassembling and assembling.

If a cleaning fluid is applied for cleaning, it must be checked that the hose element liner material is resistant to that.



When solidifying products are pumped, it is necessary to clean the inlet pulse accumulator hose element immediately once the pump is stopped, to avoid solidification and hardening of the product within the hose element.

6.2 Removing the inlet pulse accumulator hose element

1. Disconnect the electrical supply from the corresponding pump and close any valves to minimise product loss.
2. Position a tray under the inlet pulse accumulator. This tray must be sufficiently large to collect all liquid product inside the inlet pulse accumulator.



WARNING

If the inlet pulse accumulator hose element is cracked or worn, liquid product to be pumped may escape via the breather hole. Therefore, take the necessary safety precautions.

3. Support the inlet pulse accumulator in such a way that it cannot fall during disassembly.

4. Remove the mounting bolts from both flanges. Lift the inlet pulse accumulator onto a suitable workbench. Adhere to the instructions for lifting and moving as mentioned in paragraph 5.4 *Lifting and moving the inlet pulse accumulator*.
5. Remove the bolts and washers (pos. 7 and 8) from the protecting hood (pos. 1) and pull off the protecting hood.
6. Loosen the hose clamps (pos. 6) on both ends of the hose element.
7. Remove the end cap (pos. 5) from the inlet pulse accumulator hose element.
8. Remove the inlet pulse accumulator hose element from the base (pos. 3).

6.3 Replacing the inlet pulse accumulator hose element

After the inlet pulse accumulator hose element has been removed, as described in “Removing the inlet pulse accumulator hose element”, the (new) hose element can be installed in the inlet pulse accumulator.

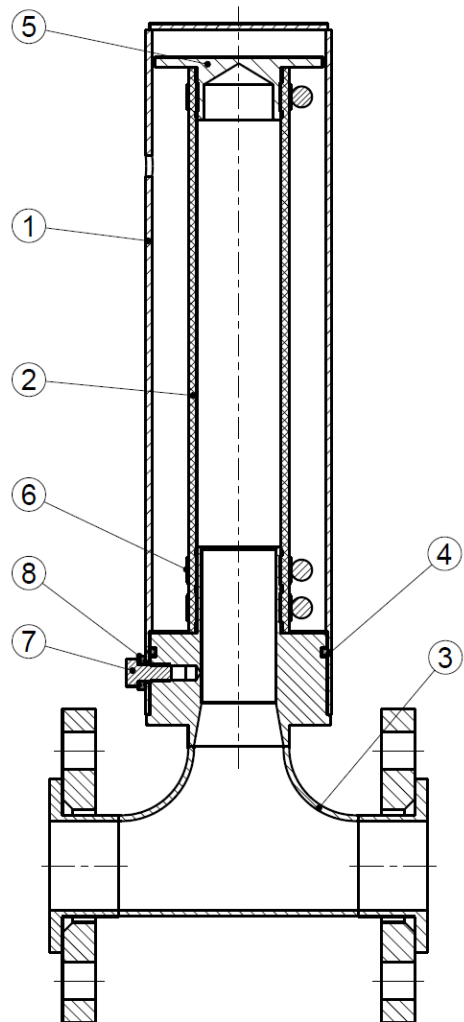

CAUTION

If you are installing a new inlet pulse accumulator hose element, and you wish to continue pumping the same product, ensure that the colour code of the new hose element matches the colour code of the old, used hose element.

1. Check all parts to be installed for any damage and replace when necessary.
2. Grease all metal parts which are not corrosion-protected and O-rings with Molykote® 55M or equivalent.
3. Loosely place the hose clamps (pos. 6) at both ends of the inlet pulse accumulator hose element. For IPA40 and IPA65 one hose clamp at the top hose element end (near the end cap) is required; for IPA100 two hose clamps at the top hose element end. At the base side hose element end two clamps are required.
4. Place the hose element on the base.
5. Place the end cap (pos. 5) on the free hose element end.
6. Tighten all hose clamps (pos. 6) with the proper torque values.
7. Check if the thin O-ring (pos. 4) is in the groove in the base. Replace if necessary.
8. Place the protection hood over the hose element and end cap onto the base (pos. 3). The end cap should be free and not touching the interior of the protection hood top. Ensure that the hose element has the proper length and that the hose element is shifted on the base and end cap till it touches the end faces.
9. Place bolts and washers (pos. 7 and 8) and tighten them with the proper torque values.
10. Lift the inlet pulse accumulator from the work bench and place it back into the pipe work. Observe the instructions for lifting and moving as mentioned in paragraph 5.4 *Lifting and moving the inlet pulse accumulator*. Mount and tighten the mounting bolts to the flanges at both ends.

7 TROUBLESHOOTING

If the inlet pulse accumulator does not function (correctly), consult the following checklist to see if you can remedy the problem yourself. If you cannot, please contact your Bredel representative.

Problem	Possible cause	Solution
Product leakage	Not all parts have been greased properly.	Grease all necessary parts. See also paragraph 6.3 <i>Replacing the inlet pulse accumulator hose element</i> .
Short inlet pulse accumulator hose element life	Chemical corrosion of the hose element	Check the compatibility of the hose element material with the product to be pumped. Consult your Bredel representative for correct hose element selection.
	High inlet pressures	Maximum operating pressure is 350 kPa (3.5 bar, 50 psi). Check whether the inlet pressure is too high. Check the height of the input reservoir level if applicable.
	High product temperature	Consult your Bredel representative for correct inlet pulse accumulator hose element selection.
High pulsations	Poorly optimized conditions	Restructure the discharge and inlet conditions.
	Malfunctioning inlet pulse accumulator	Check the inlet pulse accumulator interior for any solidified products or hose element damage.

8 SPECIFICATIONS

8.1 General information

Description	Value	
Maximum allowable working pressure inlet line before inlet pulse accumulator	350 kPa	50 psi
Allowable ambient temperature	-20 to +45 °C	-4 to +113 °F
Allowable product temperature	-10 to +80 °C	+14 to +176 °F
Allowable storage temperature	-40 to +70 °C	-40 to +158 °F

8.2 Torque values

Component	Description	Unit	IPA40	IPA65	IPA100
Hose clamp (pos. 6)	Torque value ¹⁾	Nm	2 - 4	2 - 4	2 - 4
		lbf in	18 - 35	18 - 35	18 - 35
Protection hood bolts (pos. 7)	Thread		M8	M8	M8
	Torque value	Nm	4	4	4
		lbf in	35	35	35
Connecting flange	Thread		M8	M10	M12
	Torque value	Nm	25	50	85
		lbf in	220	440	750

1) Minimum torque value based on new clamps with smooth thread.

See also chapter 6.3 *Replacing the inlet pulse accumulator hose element* for extra instruction on hose clamp installation.

8.3 Weights

Description	Unit	IPA40	IPA65	IPA100
Inlet pulse accumulator steel version, complete	kg	9.1	17.3	34.5
	lbs	20	38	76
Inlet pulse accumulator PVC version, complete	kg	3.8	10	25
	lbs	8.4	22	55
Hose element	kg	0.17	0.7	1.4
	lbs	0.37	1.5	3.1

8.4 Parts list

For position numbers see the drawings in paragraphs 8.5 *Dimensions Stainless Steel version* and 8.6 *Dimensions PVC version*.

IPA40

Pos.	Qty.	Description	Item no.
1	1	Protection hood	
2	1	Pulsation hose element	See paragraph 4.4 <i>Inlet pulse accumulator hose element</i>
3	1	Connection base	
4	1	O-ring	28-S122351
5	1	End cap	
6	3	Hose clamp	28-C111509
7	3	Hexagon screw	28-F504053
8	3	Washer PA6	28-F724006

IPA65

Pos.	Qty.	Description	Item no.
1	1	Protection hood	
2	1	Pulsation hose element	See paragraph 4.4 <i>Inlet pulse accumulator hose element</i>
3	1	Connection base	
4	1	O-ring	28-S123430
5	1	End cap	
6	3	Hose clamp	28-C111512
7	3	Hexagon screw	28-F504053
8	3	Washer PA6	28-F724006

IPA100

Pos.	Qty.	Description	Item no.
1	1	Protection hood	
2	1	Pulsation hose element	See paragraph 4.4 <i>Inlet pulse accumulator hose element</i>
3	1	Connection base	
4	1	O-ring	28-S123510
5	1	End cap	
6	4	Hose clamp	28-C111515
7	6	Hexagon screw	28-F504053
8	6	Washer PA6	28-F724006

8.5 Dimensions Stainless Steel version

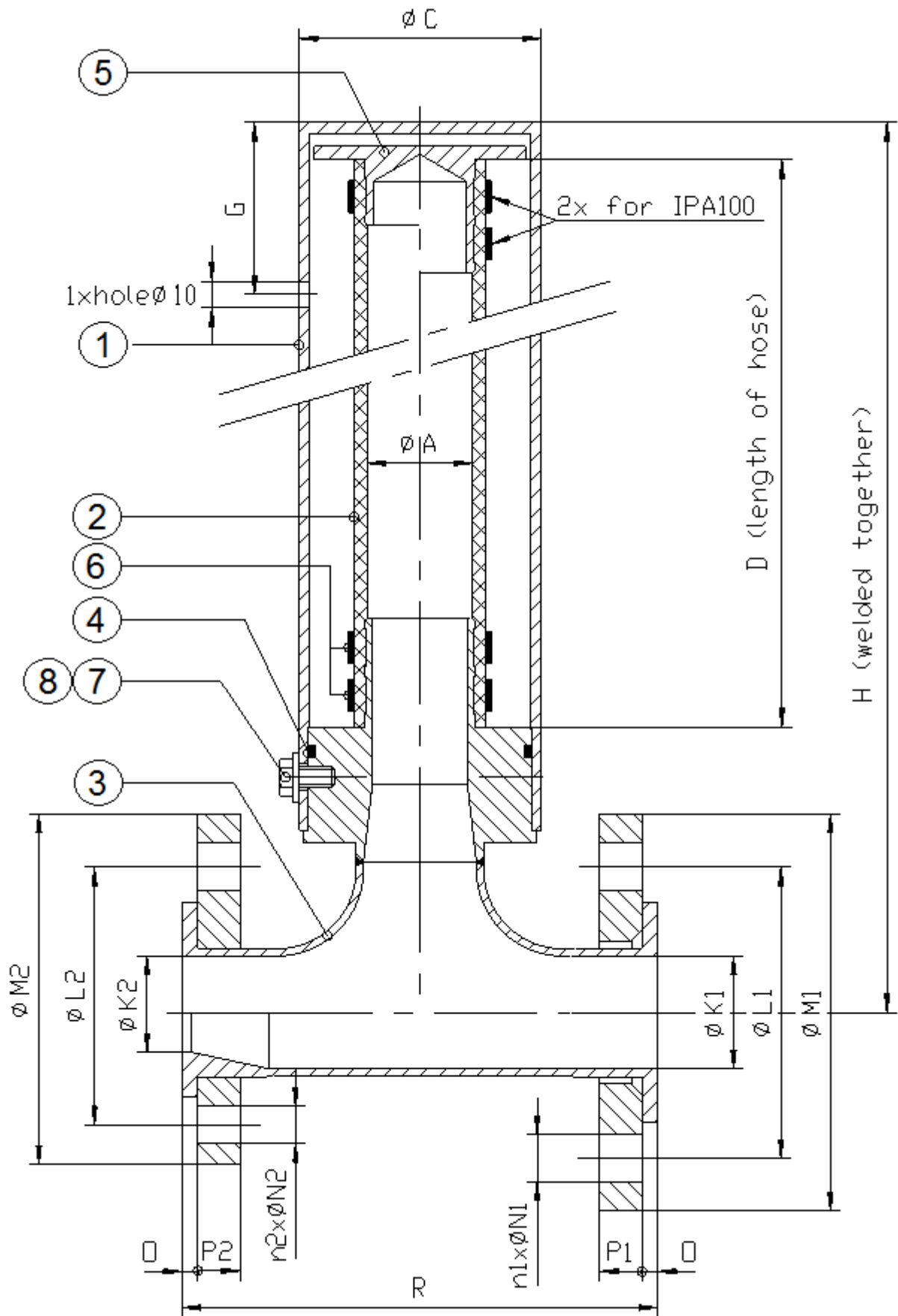

Stainless steel version with flanges acc. to EN 1092, dimensions in [mm]

Damper Type	Pump Type	A	C	D	G	H	K1	L1	M1	n1	N1	P1	K2	L2	M2	n2	N2	P2	O	R
IPA40	Bredel 25	40	89	270	65	402	42	110	150	4	18	16	30	85	115	4	14	16	6	180
	Bredel 32												36	100	140	4	18	16		
	Bredel 40												42	110	150	4	18	16		
IPA65	Bredel 50	65	108	345	75	511	67	145	185	8	18	16	54	125	165	4	18	16	6	212
	Bredel 65			525		694							67	145	185	8	18	16		
IPA100	Bredel 80	100	140	575	95	776	102	180	220	8	18	18	82	160	200	8	18	18	8	276
	Bredel 100			730		931							102	180	220	8	18	18		

Stainless steel version with flanges acc. to EN 1092, dimensions in [inch]

Damper Type	Pump Type	A	C	D	G	H	K1	L1	M1	n1	N1	P1	K2	L2	M2	n2	N2	P2	O	R
IPA40	Bredel 25	1.57	3.50	10.6	2.56	15.8	1.65	4.33	5.91	4	0.71	0.63	1.18	3.35	4.53	4	0.55	0.63	0.24	7.09
	Bredel 32												1.42	3.94	5.51	4	0.71	0.63		
	Bredel 40												1.65	4.33	5.91	4	0.71	0.63		
IPA65	Bredel 50	2.56	4.25	13.6	2.95	20.1	2.64	5.71	7.28	8	0.71	0.63	2.13	4.92	6.50	4	0.71	0.63	0.24	8.35
	Bredel 65			20.7		27.3							2.64	5.71	7.28	8	0.71	0.63		
IPA100	Bredel 80	3.94	5.51	22.6	3.74	30.6	4.02	7.09	8.66	8	0.71	0.71	3.23	6.30	7.87	8	0.71	0.71	0.31	10.9
	Bredel 100			28.7		36.7							4.02	7.09	8.66	8	0.71	0.71		

Stainless steel version with flanges acc. to ANSI, dimensions in [mm]

Damper Type	Pump Type	A	C	D	G	H	K1	L1	M1	n1	N1	P1	K2	L2	M2	n2	N2	P2	O	R
IPA40	Bredel 25	40	89	270	65	402	42	98.4	127	4	15.9	16	30	79.4	108	4	15.9	14	6	180
	Bredel 32												36	88.9	118	4	15.9	15		
	Bredel 40												42	98.4	127	4	15.9	16		
IPA65	Bredel 50	65	108	345	75	511	67	140	178	8	19	16	54	121	152	4	19	16	6	212
	Bredel 65			525		694							67	140	178	8	19	16		
IPA100	Bredel 80	100	140	575	95	776	102	191	229	8	19	18	82	152	191	8	19	18	8	276
	Bredel 100			730		931							102	191	229	8	19	18		

Stainless steel version with flanges acc. to ANSI, dimensions in [inch]

Damper Type	Pump Type	A	C	D	G	H	K1	L1	M1	n1	N1	P1	K2	L2	M2	n2	N2	P2	O	R
IPA40	Bredel 25	1.57	3.50	10.6	2.56	15.8	1.65	3.87	5.00	4	0.63	0.63	1.18	3.13	4.25	4	0.63	0.55	0.24	7.09
	Bredel 32												1.42	3.50	4.63	4	0.63	0.59		
	Bredel 40												1.65	3.87	5.00	4	0.63	0.63		
IPA65	Bredel 50	2.56	4.25	13.6	2.95	20.1	2.64	5.50	7.00	8	0.75	0.63	2.13	4.75	6.00	4	0.75	0.63	0.24	8.35
	Bredel 65			20.7		27.3							2.64	5.50	7.00	8	0.75	0.63		
IPA100	Bredel 80	3.94	5.51	22.6	3.74	30.6	4.02	7.50	9.00	8	0.75	0.71	3.23	6.00	7.50	8	0.75	0.71	0.31	10.9
	Bredel 100			28.7		36.7							4.02	7.50	9.00	8	0.75	0.71		

8.6 Dimensions PVC version

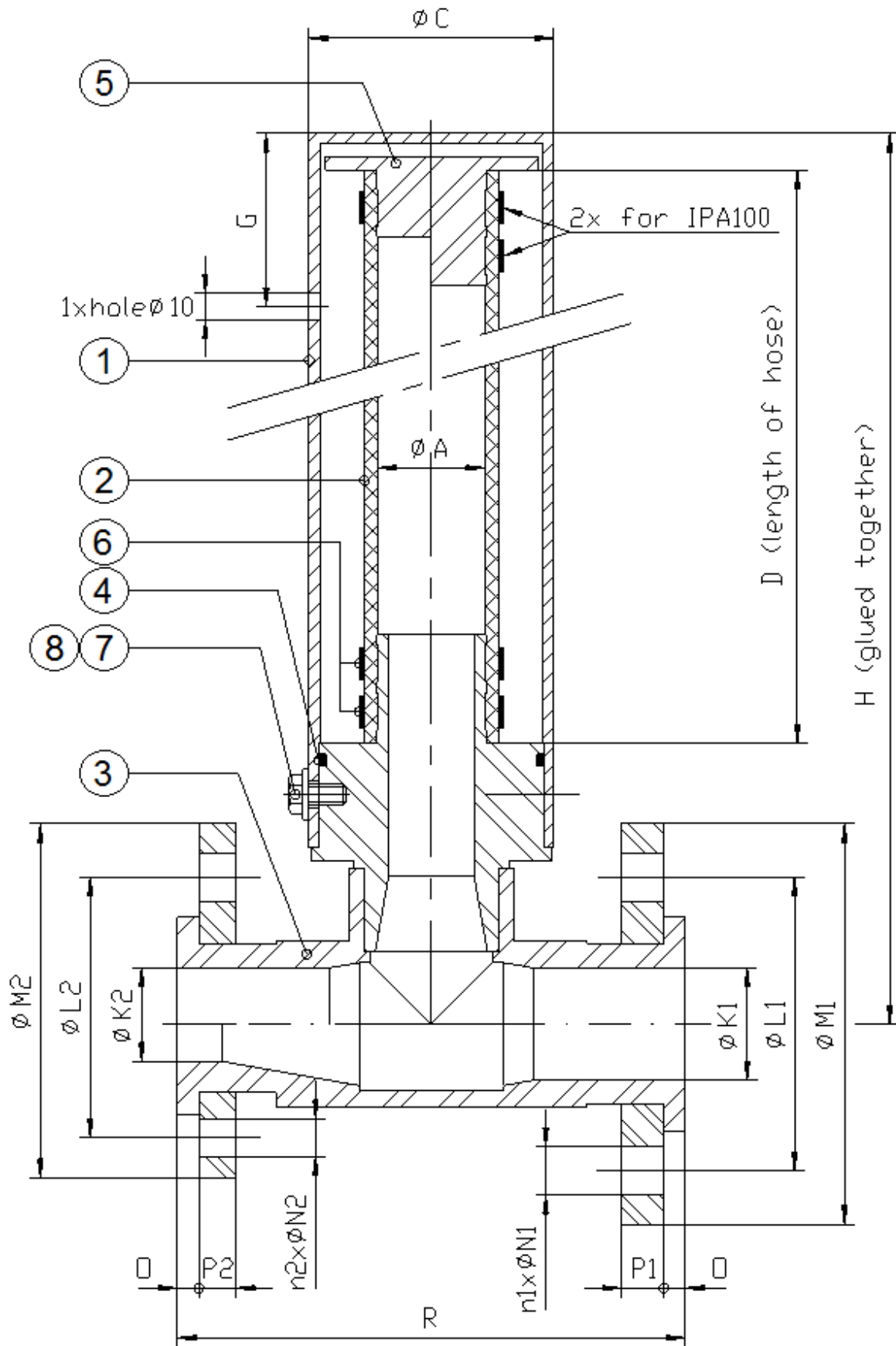

PVC version with flanges acc. to EN 1092, dimensions in [mm]

Damper Type	Pump Type	A	C	D	G	H	K1	L1	M1	n1	N1	P1	K2	L2	M2	n2	N2	P2	O	R
IPA40	Bredel 25	40	89	270	65	396	42	110	150	4	18	16	28	85	115	4	14	14	8	190
	Bredel 32												34	100	140	4	18	15		
	Bredel 40												42	110	150	4	18	16		
IPA65	Bredel 50	65	108	345	75	513	68	145	185	8	18	19	52	125	165	4	18	18	10	270
	Bredel 65			525		696							68	145	185	4	18	19		
IPA100	Bredel 80	100	140	575	95	791	103	180	220	8	18	22	82	160	200	8	18	18	12	390
	Bredel 100			730		946							103	180	220	8	18	22		

PVC version with flanges acc. to EN 1092, dimensions in [inch]

Damper Type	Pump Type	A	C	D	G	H	K1	L1	M1	n1	N1	P1	K2	L2	M2	n2	N2	P2	O	R
IPA40	Bredel 25	1.57	3.50	10.6	2.56	15.6	1.65	4.33	5.91	4	0.71	0.63	1.10	3.35	4.53	4	0.55	0.55	0.31	7.48
	Bredel 32												1.34	3.94	5.51	4	0.71	0.59		
	Bredel 40												1.65	4.33	5.91	4	0.71	0.63		
IPA65	Bredel 50	2.56	4.25	13.6	2.95	20.2	2.68	5.71	7.28	8	0.71	0.75	2.05	4.92	6.50	4	0.71	0.71	0.39	10.6
	Bredel 65			20.7		27.4							2.68	5.71	7.28	4	0.71	0.75		
IPA100	Bredel 80	3.94	5.51	22.6	3.74	31.1	4.06	7.09	8.66	8	0.71	0.87	3.23	6.30	7.87	8	0.71	0.71	0.47	15.4
	Bredel 100			28.7		37.2							4.06	7.09	8.66	8	0.71	0.87		

PVC version with flanges acc. to ANSI, dimensions in [mm]

Damper Type	Pump Type	A	C	D	G	H	K1	L1	M1	n1	N1	P1	K2	L2	M2	n2	N2	P2	O	R
IPA40	Bredel 25	40	89	270	65	396	42	98.4	127	4	15.9	18	28	79.4	108	4	15.9	18	8	190
	Bredel 32							34					88.9	118	4	15.9	18			
	Bredel 40							42					98.4	127	4	15.9	18			
IPA65	Bredel 50	65	108	345	75	513	68	140	178	8	19	20	52	121	152	4	20	20	10	270
	Bredel 65			525		696		68					140	178	8	19	20			
IPA100	Bredel 80	100	140	575	95	791	103	191	229	8	20	20	82	152	191	8	20	20	12	390
	Bredel 100			730		946		103					191	229	8	20	20			

PVC version with flanges acc. to ANSI, dimensions in [inch]

Damper Type	Pump Type	A	C	D	G	H	K1	L1	M1	n1	N1	P1	K2	L2	M2	n2	N2	P2	O	R
IPA40	Bredel 25	1.57	3.50	10.6	2.56	15.6	1.65	3.87	5.00	4	0.63	0.71	1.10	3.13	4.25	4	0.63	0.71	0.31	7.48
	Bredel 32							1.34					3.50	4.63	4	0.63	0.71			
	Bredel 40							1.65					3.87	5.00	4	0.63	0.71			
IPA65	Bredel 50	2.56	4.25	13.6	2.95	20.2	2.68	5.50	7.00	8	0.75	0.79	2.05	4.75	6.00	4	0.79	0.79	0.39	10.6
	Bredel 65			20.7		27.4		2.68					5.50	7.00	8	0.75	0.79			
IPA100	Bredel 80	3.94	5.51	22.6	3.74	31.1	4.06	7.50	9.00	8	0.79	0.79	3.23	6.00	7.50	8	0.79	0.79	0.47	15.4
	Bredel 100			28.7		37.2		4.06					7.50	9.00	8	0.79	0.79			

9 SAFETY FORM



WARNING

A complaint will only be handled by Bredel if this Safety Form is fully completed and digitally send to Bredel before shipment is activated. A hardcopy of this form is to be attached to the outside of the packaging including MSDS sheet or similar safety information sheet if applicable for each item returned.

Product Use and Decontamination Declaration

TS16-002 rev. 0

In compliance with our **Health & Safety Regulations**, the user is required to declare any substances that have been in contact with the item(s) being returned to Watson-Marlow Bredel B.V. or any of its subsidiaries or distributors. Not following these requirements may lead to delays in service and/ or response time. Full completion of this form assures we are provided with necessary information before receipt of the item(s) being returned. A hardcopy of the completed form must be attached to **the outside of the packaging** containing the item(s). The sender of the item(s) is responsible for cleaning and decontaminating of the item(s) before returning them in such way that it is safe for the receiver to open the packaging and handle the item(s).

Complaint number:

1. Company:
 Address: Postal code:
 Contact person: Email address:
 Telephone: Fax number:

2. Product:

2.1 Serial Number:.....

2.2 Has the Product been used?

Yes (Go to section 3)

No (Go to section 5)

3. Details of substances pumped

3.1 Chemicals names:

(a)

(b)

(c)

(d)

3.2 Precautions to be taken in handling these substances:

(a)

(b)

(c)

(d)

3.3 Actions to be taken in event of human contact:

(a)

(b)

(c)

(d)

3.4 Cleaning fluid to be used if residue of chemical is found during service:

(a)

(b)

(c)

(d)

4. I hereby confirm that the only substance(s) that the equipment specified has pumped or come into contact with those named, that the information given is correct and the carrier has been informed if the consignment is of a hazardous nature.

5. Signed:

Name:

Position:

Date:

Note:

To assist us in our service, please describe any fault condition you have witnessed.

.....

.....

.....

.....

Quantity of sheets attached:



America:

Watson-Marlow Fluid Technology Group
37 Upton Technology Park
Wilmington, MA 01887
USA
Telephone: 800 - 282 - 8823
978 - 658 - 6168
Fax: 978 - 658 - 0041
Internet: www.wmftg.com
E-mail: support@wmftg.us

Other areas:

Watson-Marlow Bredel B.V.
P.O. Box 47
NL-7490 AA Delden
The Netherlands
Phone: +31 74 3770000
Fax: +31 74 3761175
E-Mail: bredel@wmftg.com
Internet: www.bredel.com

TS16-005 rev. 0

28-1003048